

# TEMPERING & MIXING VESSEL

Stirring tank with double jacket

## Material

1.4404 (316L)

## Finishing

electropolished inside and outside

## Volumes

0.1 to 200 liters (see type overview)

## Gaskets

EPDM, silicone or PTFE

## Pressure

-1/ 5 bar

## Other

GMP-compliant documentation

## Equipment

Central Tri-Clamp nozzle with:

- **OUT/MIX** immersion tube with PTFE-coated double magnetic stirrer
- Tri-Clamp connection
- **GAS** pipe bend with Tri-Clamp connection

Above cylindrical part and bottom:

- **DOUBLE MANTLE**



Type	Material	Finishing	Volume [l]	Ø Da [mm]	H [mm]	s [mm]	Mass [kg]	Pressure [bar]
JCD 0.25 M	1.4404 (316L)	electropolished	0,3	67	200	1	3	-1/+5
JCD 0.5 M	1.4404 (316L)	electropolished	0,6	89	230	1	4	-1/+5
JCD 01 M	1.4404 (316L)	electropolished	1,4	108	250	1	4	-1/+5
JCD 02 M	1.4404 (316L)	electropolished	3	140	325	1	5	-1/+5
JCD 05 M	1.4404 (316L)	electropolished	6	181	380	1	6	-1/+5
NCD 10 M	1.4404 (316L)	electropolished	12	229	430	1,5	8	-1/+5
NCD 20 M	1.4404 (316L)	electropolished	22	278	500	1,5	15	-1/+5
NCD 30 M	1.4404 (316L)	electropolished	33	324	620	1,5	22	-1/+5
NCD 50 M	1.4404 (316L)	electropolished	53	363	700	1,5	28	-1/+5
HCD 100 M	1.4404 (316L)	electropolished	110	450	900	2	48	-1/+4
MCD 150 M	1.4404 (316L)	electropolished	160	550	950	2,5	60	-1/+4
HCD 200 M	1.4404 (316L)	electropolished	205	550	1050	2	68	-1/+4

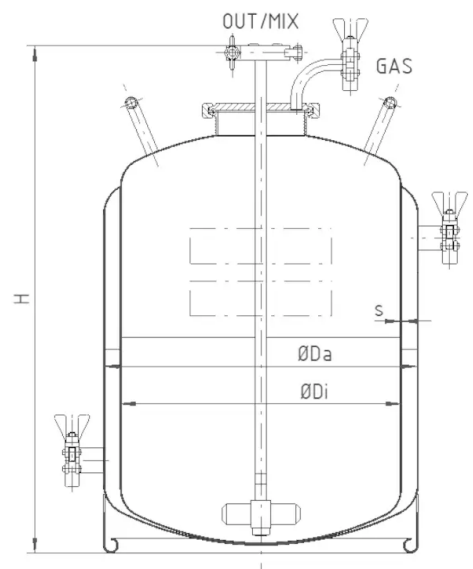

*Safety for people, product and the environment*



Dipl.-Ing. Wilhelm Schmidt GmbH

Breslauer Str. 14

64342 Seeheim-Jugenheim

Germany

+49 6257 50 69 0

+49 6257 50 69 50

info@schmidt-seeheim.de

www.schmidt-seeheim.com